

Pharmaceutical Plastic Packaging Tablet Packaging

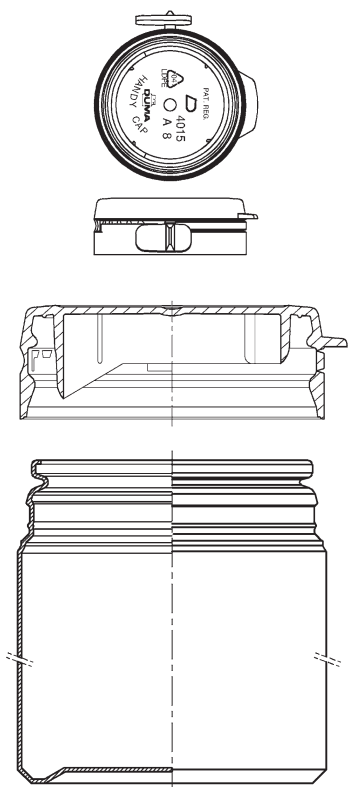

Duma® Special



031030	30	36	54	56	21	31	2813	
043050	50	45	51	53	33	32	4015	4015T
043075	75	45	68	70	33	49	4015	4015T
043100	100	45	85	88	33	66	4015	4015T
043135	135	45	106	108	33	88	4015	4015T
043150	150	45	120	123	33	101	4015	4015T
065150	150	67	70	72	54	44	6017	
065250	250	67	90	93	54	65	6017	
065300	300	67	113	116	54	88	6017	
065400	400	67	144	146	54	115	6017	
065500	500	67	177	179	54	151	6017	
095500	500	100	92	95	82	61	9022	

*Int. Des. – integrated desiccant

▶ Continued on page 3.9

Pharmaceutical Plastic Packaging Tablet Packaging



Duma® Special (cont.)

► Continued from page 3.8

095750	750	100	124	126	82	93	9022
951000	1000	100	155	158	82	124	9022
951250	1250	100	187	189	82	153	9022
951500	1500	100	218	220	82	185	9022

*Int. Des. – integrated desiccant

Material:

Container HDPE, cap LDPE

16 sizes ranging from 30-1500 ml

- Snap lock system
- Wide neck design
- Handy Cap easy-open system
- Caps available in various colours
- FDA registered, DMF type III, DMF no. 12077
- Tamper-evident
- Available with integrated desiccant 0.5 - 6 gr.
- Containers produced by injection blow moulding /blow moulding
- Caps produced by injection moulding
- Manufactured under clean-room conditions

